

# PANTHELLA 320 TABLE LAMP

The fixture emits a soft, comfortable, glare-free, light. The metal-shade versions direct the light directly downward, creating a pleasant illumination due to the inner white-painted shade and the reflection from the trumpet-shaped stem. The opal acrylic produces a diffused, comfortable light due to the translucent shade, the downward reflection from the inner shade, and the reflection from the trumpet-shaped stem.

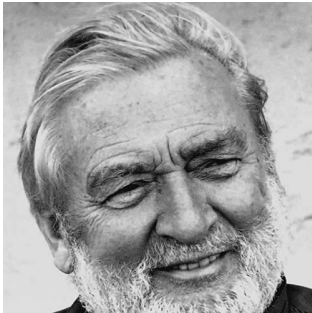

## Verner Panton

Verner Panton (1926-1998) is famous for his inspirational and colorful personality. A unique person with a special sense for color, shape, light function and space. Over the course of his career, Panton introduced a series of modern lamps with personalities unlike any of his Scandinavian contemporaries.



## Product info

### Information

White cord on white opal and metallised brass versions. Black cord on grey opal and chrome versions.

### Mounting

Cord type: Plastic cord with plug. Cord length: 2.5 m. Light control: On/off switch on cord. Diffuser with bajonet lock.

### Finish

White opal acrylic shade with white stand. Grey opal acrylic shade with high-luster chrome stand. High-luster chrome shade and stand. Brass metallised shade and stand.

### Materials

Shade: Injection-molded acrylic or deep-drawn steel. Base and housing: Cast aluminum. Diffuser: Injection-molded opal pmma.

### Sizes and weights

Width x Height x Length (mm) | 320 x 438 x 320 Max 1.5 kg

### Class

Ingress protection IP20. Electric shock protection II.

### Light source

1x7.5W E14 Max. diameter: 48 mm Max. height: 83 mm

### Information

White cord on white opal and metallised brass versions. Black cord on grey opal and chrome versions.



## Related products



Panthella 400 Table Lamp



Panthella Floor



Panthella 250 Table Lamp

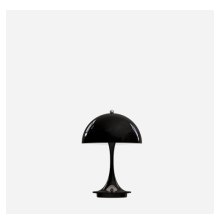

Panthella Portable Metal

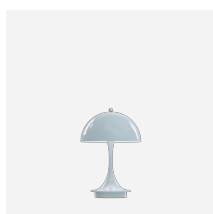

Panthella 160 Portable

## Product variants

Colour	Cable type	Light source
<ul style="list-style-type: none"> <li><span style="color: #c4c4c4;">●</span> Brass metallised</li> <li><span style="color: #808080;">●</span> Grey opal acryl</li> <li><span style="color: #404040;">●</span> High lustre chrome plated</li> <li><span style="color: #a0a0a0;">●</span> White opal acryl</li> </ul>	<ul style="list-style-type: none"> <li>Blk pl</li> <li>Wht pl</li> </ul>	1x7.5W E14

# Design

Verner Panton

# Weight

Min: 1.5 kg Max: 1.5 kg

# Finish

Brass metallised, Grey opal acryl, High lustre chrome plated, White opal acryl

# Light distribution diagrams

Cartesian

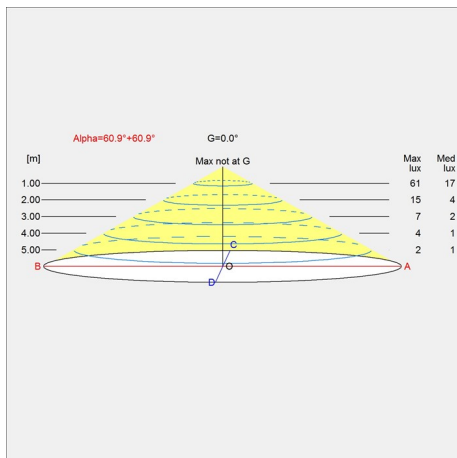

Isolux

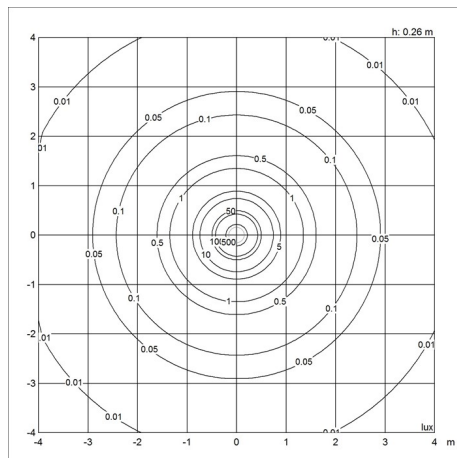

Polar

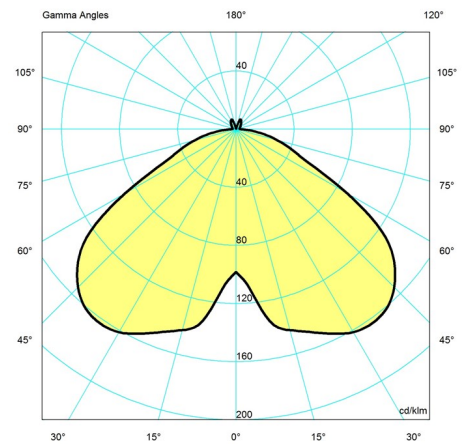

# Spare parts & accessories

## Panthella 320 Table Lamp

Product	Variant number
Panthella Table 320 diffuser	5744167592
Panthella Table 320 bayonet base	5744167602
Panthella Table 320 shade opal	5744167615
Panthella Table 320 shade brass PVD	5744167628
Panthella Table 320 shade chrome	5744167631
Panthella Table 320 top nut chrome	5744167644
Panthella Table 320 top nut brass PVD	5744167657
Panthella Table 320 shade opal grey	5744168041